

# MX•COM, INC. MiXed Signal ICs

## DATA BULLETIN

# MX439

## MSK Modem

Document #2048-0041.005 June 1995

### Features

- 1200 Baud MSK Modem
- Meets Cellular & Trunked Radio Specifications
- Full-Duplex 1200 Baud
- On-Chip RX and TX Bandpass Filters
- Clock Recovery and Carrier Detect
- Pin Selectable Xtal/Clock Frequencies

### Applications

- Mobile & Cellular Radio Data Signaling
- Personal Radio
- Portable Data Terminals
- General Purpose Applications

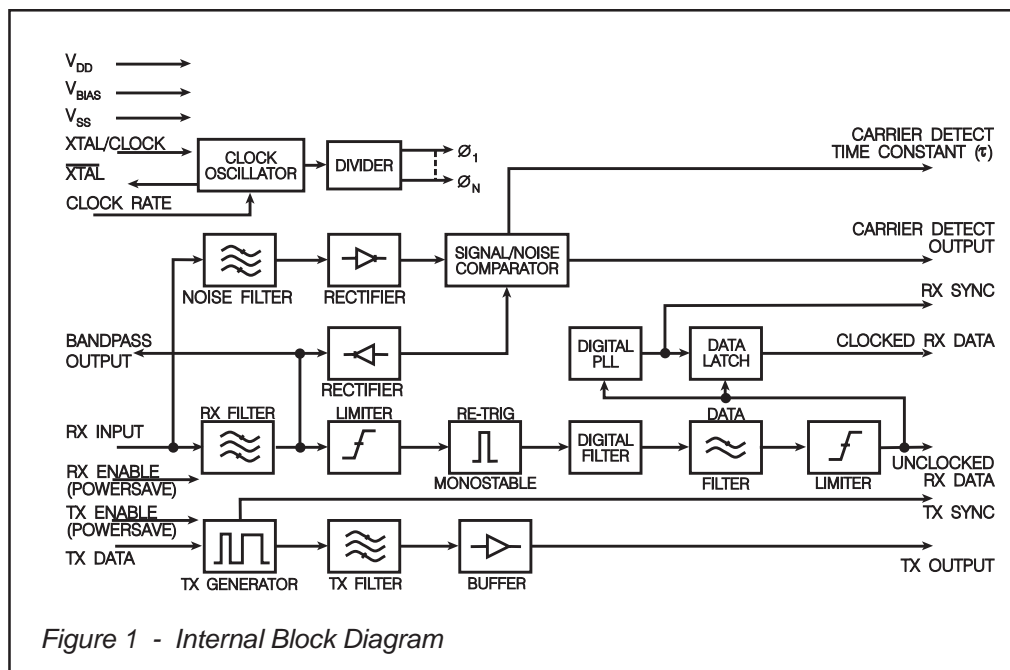

### AVAILABLE PACKAGES



**MX439LH**  
24-pin PLCC

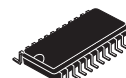

**MX439DW**  
24-pin SOIC

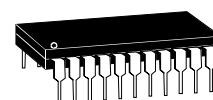

**MX439J: 22 pin CDIP**  
**MX439P: 22 pin PDIP**

### Brief Description

The MX439 is a single-chip CMOS LSI circuit which operates as a 1200 baud MSK modem. The mark and space frequencies are 1200Hz and 1800Hz phase continuous, and the frequency transitions occur at the zero crossing point. The transmitter and receiver will work independently, thus providing full-duplex operation at 1200 baud. The baud rate, transmit mark and space frequencies, and the TX and RX synchronization are all derived from a highly stable Xtal oscillator. The on-chip oscillator is capable of working at one of two input frequencies: 1.008MHz or 4.032MHz external Xtal/clock input. Frequency is pin-selectable with the "Clock Rate" logic input. The device includes circuitry for carrier detect and facility for the RX clock recovery. An on-board switched capacitor 900Hz - 2100Hz bandpass filter provides optimum carrier filtering. The use of switched capacitor analog filters and digital signal processing results in excellent dynamic performance with few external components; the CMOS process and current-saving techniques offer low standby supply current for portable battery-powered applications.

MX439P package discontinued

Pin Number			Function															
DW	J,P	LH																
1	1	1	Xtal/Clock: The input to an on-chip inverter for use with either a 1.008MHz or a 4.032MHz Xtal. Alternatively, an external clock may be used. Xtal frequency is selectable on the "Clock Rate" input pin.															
2	2	2	$\overline{\text{Xtal}}$ : Output of the on-chip inverter. (See Figure 2.)															
3	3	3	TX Sync O/P: MSK signal centered at a DC level of VBIAS - 0.7V. (See Figure 5.)															
5	5	5	TX Signal O/P: With the transmitter disabled, this pin is set to a high impedance state. When the transmitter is enabled, this pin outputs the 1200/1800Hz MSK signal centered at a DC level of VBIAS - 0.7 V. (See Figure 5.)															
7	6	7	TX Data I/P: Serial logic data to be transmitted is input to this pin and synchronized by the "TX Sync O/P." (See Figure 5.)															
8	7	8	$\overline{\text{TX Enable}}$ : A logic "1" applied to this input will put the transmitter into powersave while forcing "TX Sync O/P" to a logic "1" and "TX Signal O/P" to a high impedance state. A logic "0" will enable the transmitter (See Figure 5). This pin is internally pulled to VDD.															
9	8	9	Bandpass O/P: This is the output of the RX 900Hz-2100Hz bandpass filter. The output impedance of this pin is typically 10kW and may require buffering prior to use.															
10	9	10	RX Enable: This is the control of the RX function. The state of other outputs is given below: <table border="1" style="margin: 10px auto;"> <thead> <tr> <th>RX Enable</th> <th>RX Function</th> <th>Clock Data O/P</th> <th>Carrier Detect</th> <th>RX Sync Out</th> </tr> </thead> <tbody> <tr> <td>"1"</td> <td>Enabled</td> <td>Enabled</td> <td>Enabled</td> <td>Enabled</td> </tr> <tr> <td>"0"</td> <td>Powersave</td> <td>"0"</td> <td>"0"</td> <td>"1" or "0"</td> </tr> </tbody> </table> <p>When both TX and RX functions are disabled, the bias voltage is switched internally to VSS and Bias pin output impedance is approximately 12.5kW. When the Bias pin is decoupled by a 1.0mF capacitor (C2) the MX439 may require up to 25ms to establish correct operation after enabling the RX function. This period may be decreased by either reducing the value of C2, lowering the Bias pin impedance externally, or adopting a different powersaving strategy (such as using C2 and C5 and supplying VDD via a series switch). This pin is internally pulled to VDD.</p>	RX Enable	RX Function	Clock Data O/P	Carrier Detect	RX Sync Out	"1"	Enabled	Enabled	Enabled	Enabled	"0"	Powersave	"0"	"0"	"1" or "0"
RX Enable	RX Function	Clock Data O/P	Carrier Detect	RX Sync Out														
"1"	Enabled	Enabled	Enabled	Enabled														
"0"	Powersave	"0"	"0"	"1" or "0"														
11	10	11	Bias: Provides bias internally and should be decoupled externally to Vss by capacitor (C2). (See Fig. 2.)															
12	11	12	Vss: Negative supply rail (GND).															
13	12	13	Unlocked Data O/P: This pin outputs recovered asynchronous serial data from the receiver.															
14	13	14	Clocked Data O/P: This pin outputs recovered synchronous serial data from the receiver and is internally latched out by a recovered clock appearing on the "RX Sync O/P" pin. (See Figure 6.)															
15	14	15	Carrier Detect O/P: This pin will output a logic "1" when an MSK signal is being received.															
16	15	16	RX Signal I/P: This is the MSK signal input for the receiver. It should be decoupled using capacitor C3.															
18	17	18	RX Sync O/P: This is a flywheel 1200Hz squarewave output which, upon presentation of the MSK data signal, is synchronized internally to the incoming data. (See Figure 6.)															

Pin Number			Function
DW	J,P	LH	
21	19	21	Clock Rate: This logic input selects and allows the use of either a 1.008MHz or 4.032MHz Xtal/clock input to the on-chip inverter. Logic "1" = 4.032MHz; logic "0" = 1.008MHz. This input has an internal pulldown resistor (1.008MHz).
22	20	22	Carrier Detect Time Constant (t): This input forms part of the carrier detect integration function. The value of C4 connected to this pin will affect the carrier detect response time and hence noise performance. (See Figure 2, Note 3.)
24	22	24	VDD: Positive supply rail. A single 5 volt supply is required.
4,6,17 19,20 23	4,16, 18,21	4,6,17 19,20, 23	) ) No Connection. )

Note: Output Loading. Large capacitive loads could cause the output pins of this device to oscillate. If capacitive loads in excess of 200pF are unavoidable, a resistor of (typically) 100W put in series with the load should minimize this effect.

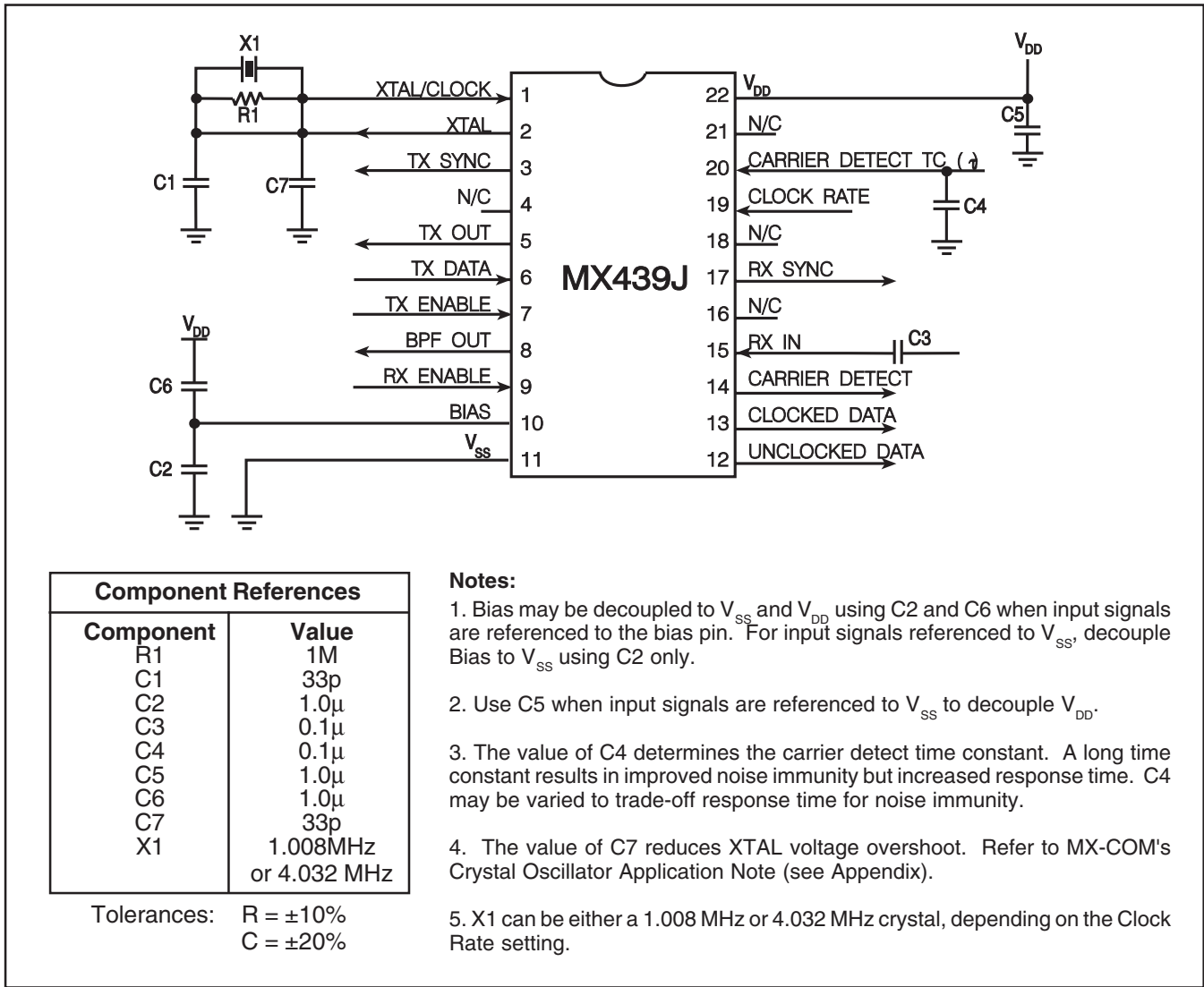

Figure 2 - External Component Connections

# DIAGRAMS

Figure 3 - Typical Variation of "B.E.R." with Input Signal Level

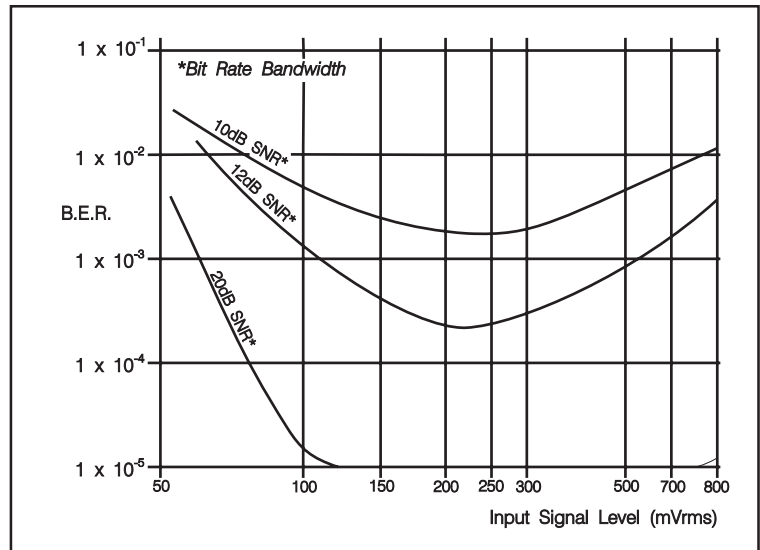

Figure 4 - MX439 Test Set-up

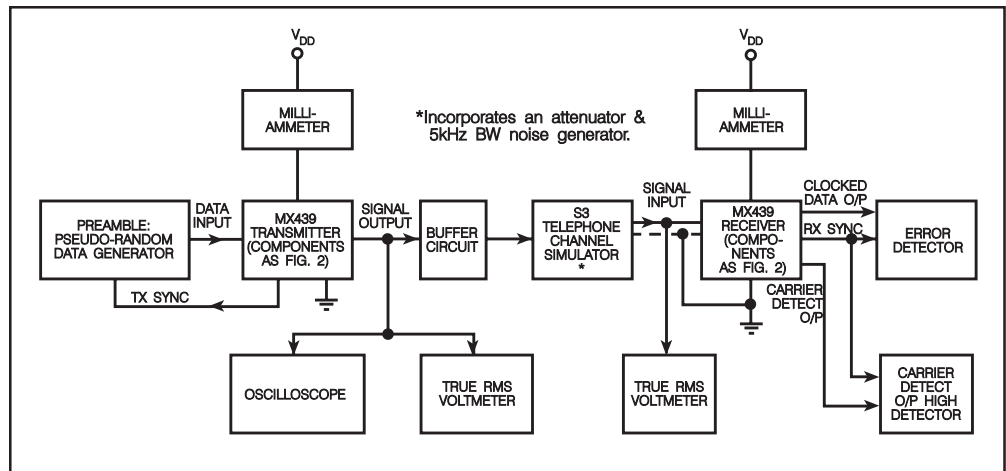
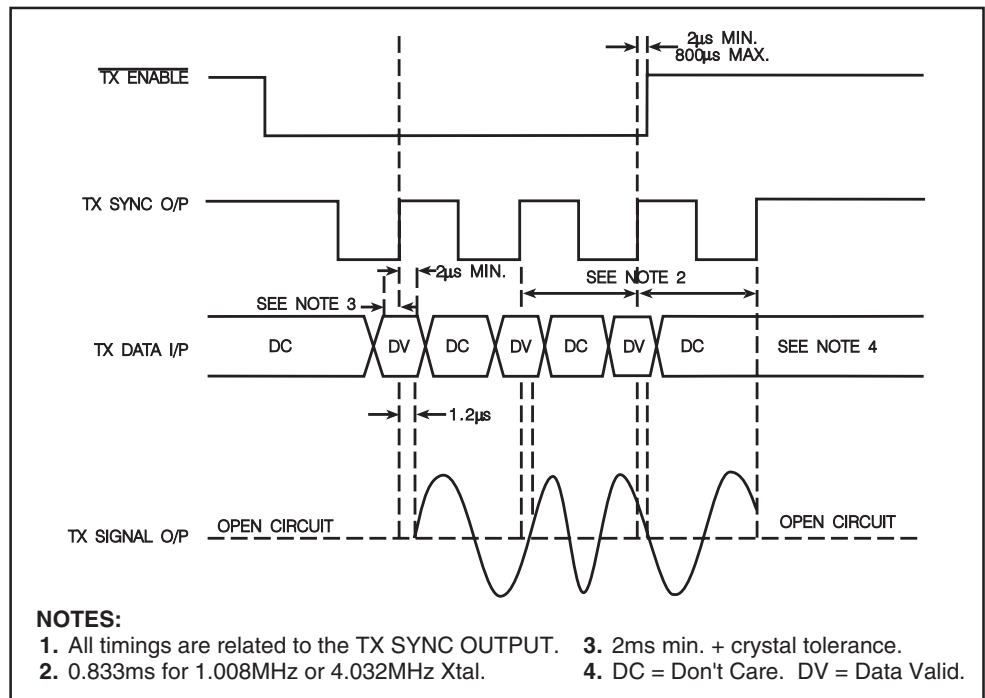

Figure 5 - Transmitter Timing Diagram



# SPECIFICATIONS

## ABSOLUTE MAXIMUM RATINGS

Exceeding the maximum rating can result in device damage. Operation of the device outside the operating limits is not suggested.

Supply Voltage	-0.3 to 7.0 V
Input Voltage at any pin (ref $V_{SS} = 0V$ )	-0.3 V to $V_{DD} + 0.3 V$
Sink/Source Current (Total)	20mA
Total Device Dissipation @ $T_{AMB} = 25^{\circ}C$	800mW max.
Derating	10 mW/ $^{\circ}C$
Operating Temperature	-40 $^{\circ}C$ to +85 $^{\circ}C$
Storage Temperature	-55 $^{\circ}C$ to +125 $^{\circ}C$

## OPERATING LIMITS

All characteristics are measured using the standard test circuit (Figure 4) with the following test parameters and is valid for all tests unless otherwise stated:

$V_{DD} = +5V$
$T_{AMB} = 25^{\circ}C$
Xtal (X1) Frequency: 1.008MHz
0dB reference = 300 mVrms
Noise (band limited 5kHz gaussian white noise)
SNR ratio measured in bit rate bandwidth (1200Hz)

## Characteristics

	See Note	Min.	Typ.	Max.	Unit
<b>Static Values</b>					
Supply Volts		4.5	5.0	5.5	V
Supply Current:					
RX Enabled, TX Disabled		-	3.6	-	mA
RX Enabled, TX Enabled		-	4.5	-	mA
RX Disabled, TX Disabled		-	650	-	$\mu A$
Logic "1" level		80% $V_{DD}$	-	-	V
Logic "0" level	-	-	-	20% $V_{DD}$	V
Digital Output Impedance		-	4	-	k $\Omega$
Analog and Digital Input Impedance		100	-	-	k $\Omega$
TX Output Impedance		-	10	-	k $\Omega$
On-Chip Crystal Oscillator:					
$R_{in}$		10	-	-	M $\Omega$
$R_{out}$		5	-	15	k $\Omega$
Inverter Gain		10	-	20	dB
Gain Bandwidth Product		$3 \times 10^6$	-	-	
Crystal Frequency	1,9	-	1.008	-	MHz
Crystal Frequency	1,10	-	4.032	-	MHz
<b>Dynamic Values</b>					
Receiver:					
Signal Input: Dynamic Range (50dB SNR)	2,3	100	230	1000	mVrms
Bit Error Rate:					
12dB SNR	3	-	7.0	-	$10^{-4}$
20dB SNR	3	-	1.0	-	$10^{-8}$
Receiver Synchronization 12dB SNR:	6				
Probability of Bit 8 being correct			99	-	%
Probability of Bit 16 being correct			99.5	-	%
Carrier Detect	4				
Sensitivity	6,7	-	-	125	mVrms
Probability of Carrier Detect being high:					
12dB SNR after Bit 8	4,8	-	98	-	%
12dB SNR after Bit 16	4,8	-	99.5	-	%
0dB Noise (No Signal)	8	-	5	-	%

Characteristics (cont.)	See Note	Min.	Typ.	Max.	Unit
<b>Transmitter Output</b>					
TX Output Level		760	860	960	mVrms
Output Level Variation 1200/1800Hz		0	-	±1.00	dB
Output Distortion		-	3	5	%
3rd Harmonic Distortion		-	2	3	%
Logic "1" Carrier Frequency	5	-	1200	-	Hz
Logic "0" Carrier Frequency	5	-	1800	-	Hz
<b>Isochronous Distortion</b>					
1200Hz - 1800Hz		-	25	40	µs
1800Hz - 1200Hz		-	20	40	µs

**Notes:**

1. Crystal frequency, type and tolerance depends on system requirements.
2. See Figure 3.
3. SNR (Bit Rate Bandwidth).
4. See Figure 2, Note 3.
5. Depending on crystal tolerance.
6. 101010101... pattern.
7. Measured with 100 mVrms signal (No noise).
8. 0dB level for CD probability measurements is 230mVrms.
9. Clock rate pin at logic "0."
10. Clock rate pin at logic "1."

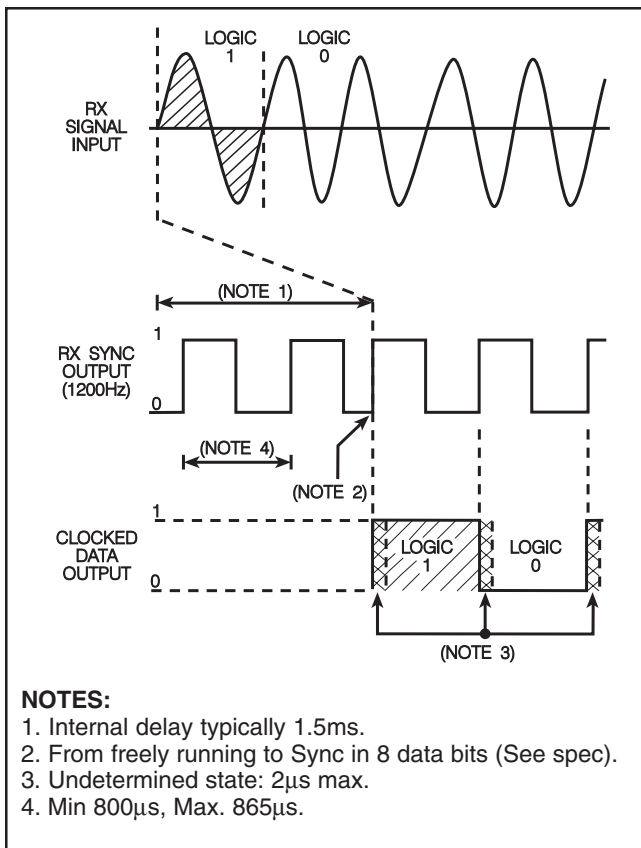

Figure 6 - Receiver Timing Diagram

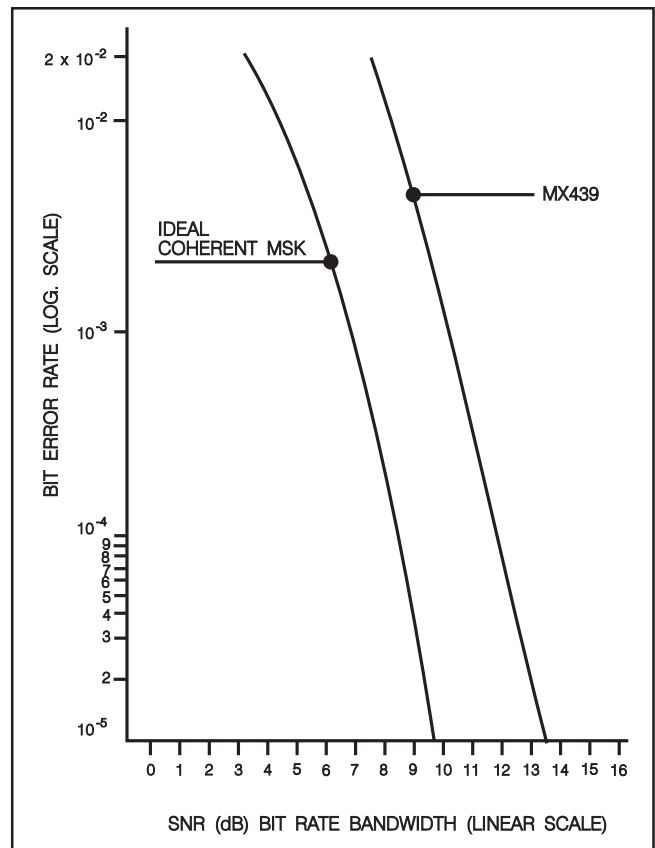

Figure 7 - Receiver B.E.R. vs SNR

# ORDERING INFORMATION

Fig.8 - MX439 LH

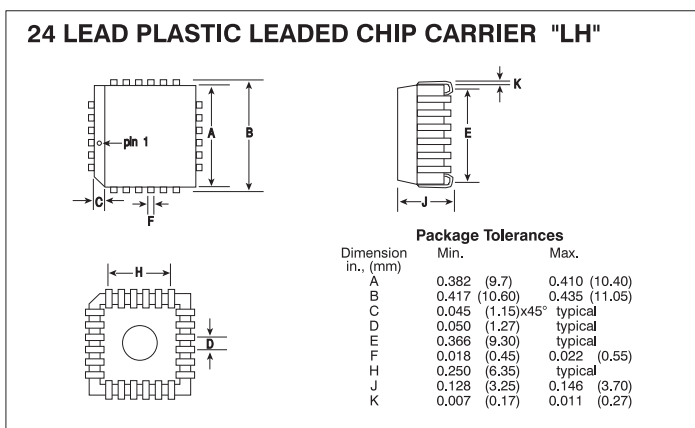

Fig.9 - MX439 DW

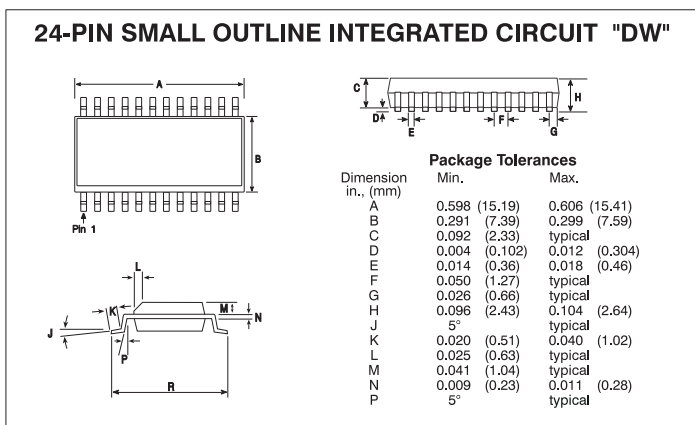

Fig.10 - MX439 P

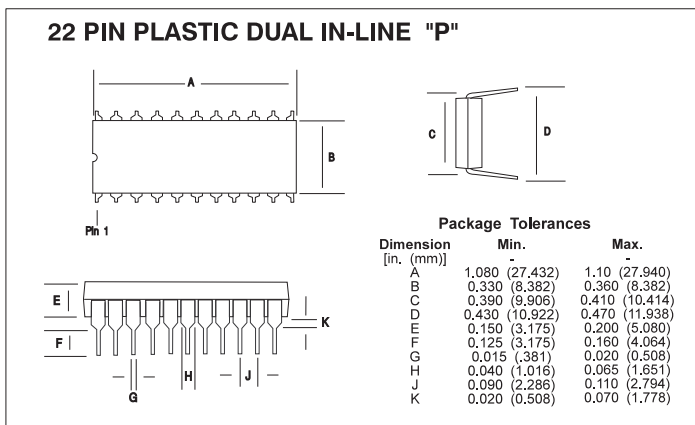
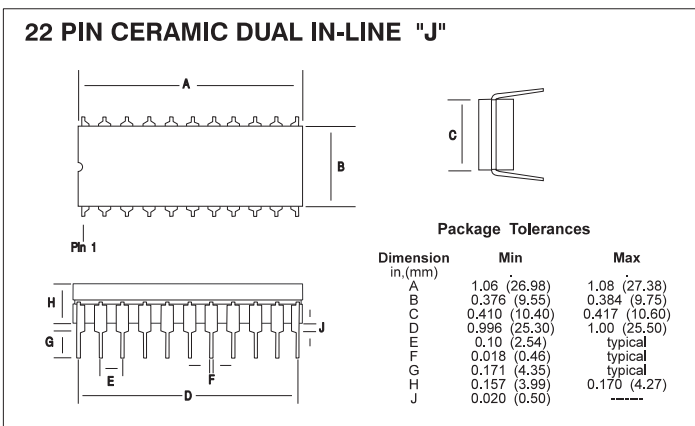

Fig.10 - MX439 J



**Package Outlines**  
 The MX439 is available in the package styles outlined on the following pages. Pin1 identification marking is shown on the relevant diagram and pins on all package styles number anti-clockwise when viewed from the top.

---

**Handling Precautions**  
 The MX429A is a CMOS LSI circuit which includes input protection. However precautions should be taken to prevent static discharges which may cause damage.

**MX•COM Mixed Signal ICs are available Worldwide!**

**Representatives:  
(by territory)**

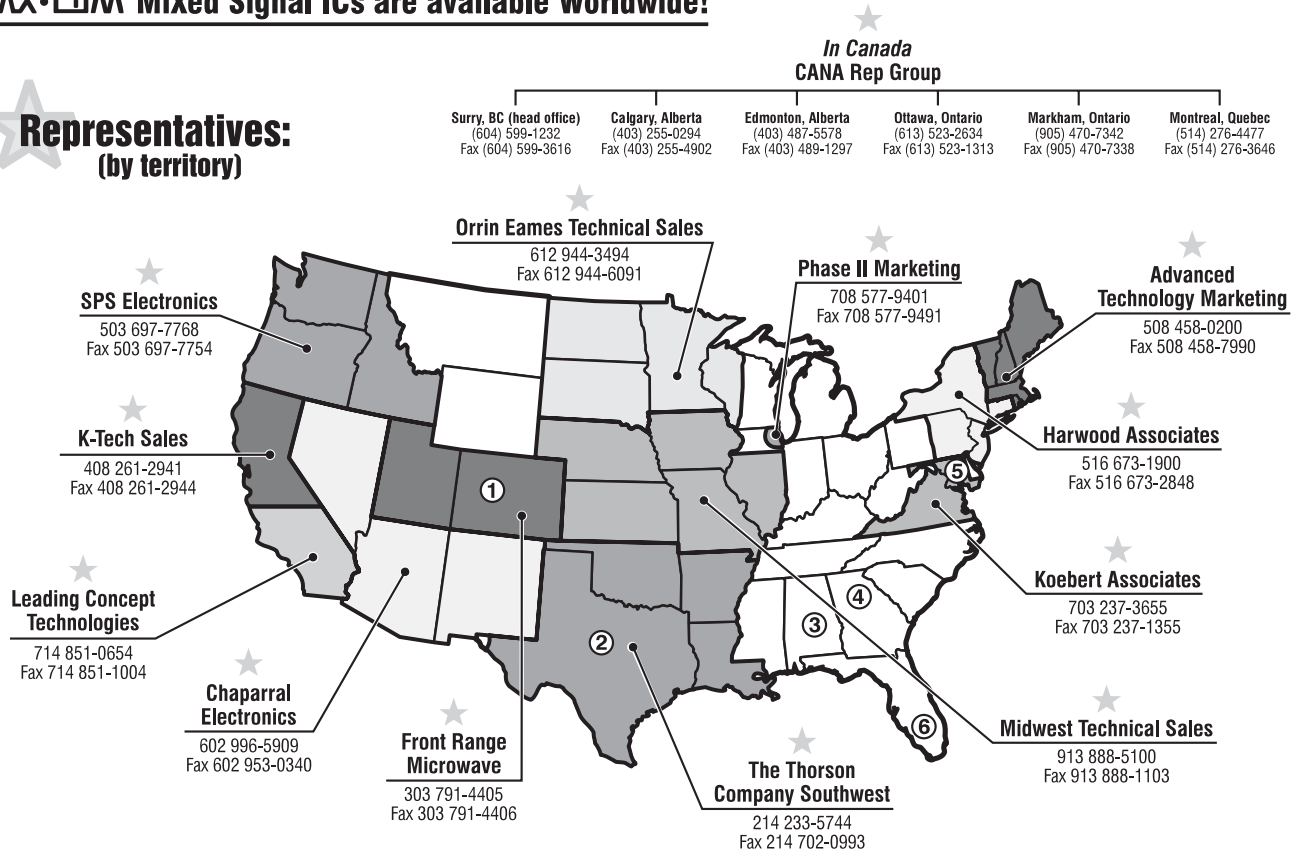

**Distributors (domestic):**

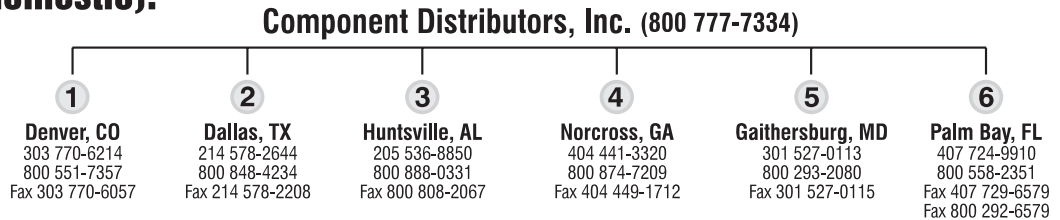

**Distributors (international):**

